

## DETR2001

Detroit 30W 3800LM 1500mm 400K IP65 LED Corrosion Proof Batten

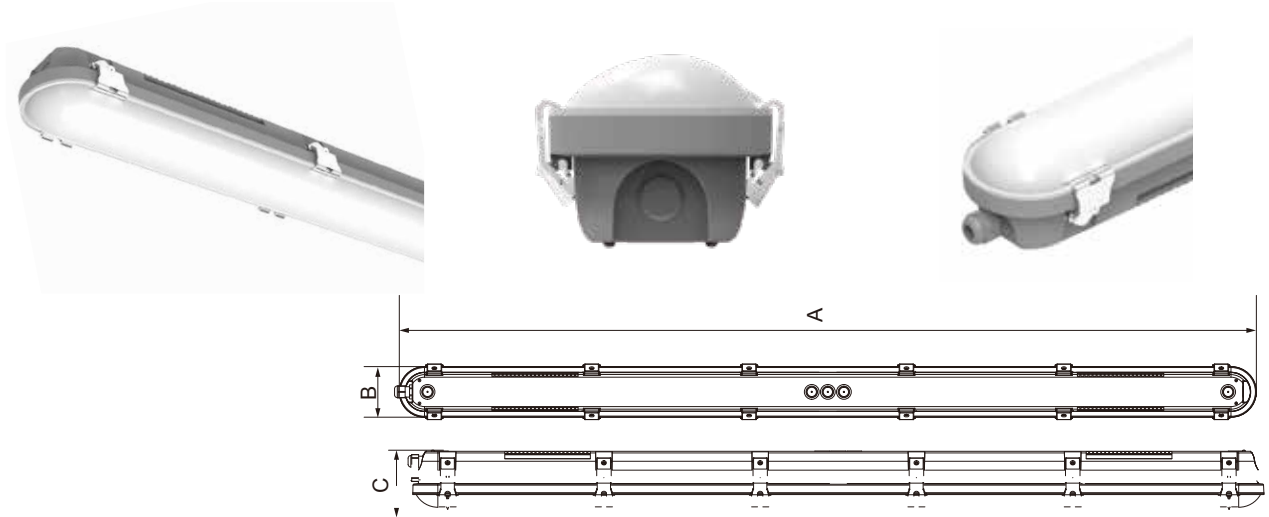

### General Details

<b>Finish</b>	Polycarbonate Body & Polycarbonate Opal Diffuser
<b>Product Weight</b>	3.8kg
<b>Overall Dimensions</b>	A 1490mm X B 73mm x C 75mm
<b>Bar Coding</b>	Saturn LED coding in accordance with EAN-12 & ITF-14
<b>IP Rating</b>	IP65
<b>Energy Rating</b>	A* - (Very Low Energy)

### Light Source

<b>Wattage &amp; Lumens</b>	30W - 3800LM - 127 lm/W
<b>Colour Temperature</b>	4000K
<b>CRI Ra</b>	Ra > 80
<b>Lifespan</b>	30,000 Hours
<b>Lamp Working Temperature</b>	<50°C
<b>Beam Angle</b>	45°



## Electrical

Voltage	220-240V. 50 / 60Hz. AC.
---------	--------------------------

Running Current (I)	110mA
---------------------	-------

Total Running Wattage (W)	30
---------------------------	----

Electrical Classification	Class II
---------------------------	----------

Power Factor Correction (PFC)	0.9
-------------------------------	-----

Cabling Electrical Connections	Screw fix in terminal block
--------------------------------	-----------------------------

LED Driver	Tridonic
------------	----------

## Installation

Method of Fix	Surface mounted on a suitable substrate.
---------------	--

Recommended Working Temperature	Minimum Temp -10°C to Maximum Temp + 40°C
---------------------------------	---

Instruction Sheet	Supplied with product
-------------------	-----------------------

## Origin & Markets

Country of Manufacture	Designed & tested in Europe - Manufactured in China
------------------------	---

Intended Market	Europe, Middle East & Australia 220 - 240Volt
-----------------	---

## Materials

Main Housing Material	Polycarbonate Cover, Acrylic Base, Stainless Steel Clips
-----------------------	--

Fixings Main Housing	Zinc plated screws (Internal)
----------------------	-------------------------------

Front Shield	Polycarbonate Opal Diffuser
--------------	-----------------------------

## Approvals

Warranty	3 Year Warranty - For more information go to <a href="http://www.saturnled.eu/warranty">www.saturnled.eu/warranty</a>
----------	---

Marks & Symbols	CE -- SELV -- RoHS -- EMC -- WEEE
-----------------	-----------------------------------

Quality Assurance System	SaturnLED quality assurance to ISO9001:2008
--------------------------	---

Manufactured in Accordance to	British Standard - BS EN 60598 - 2 - 1
-------------------------------	--

