

PHO/RHES/D

Phoenix 3W 6000K IP20 Arrow Down Recessed Hanging Exit Sign

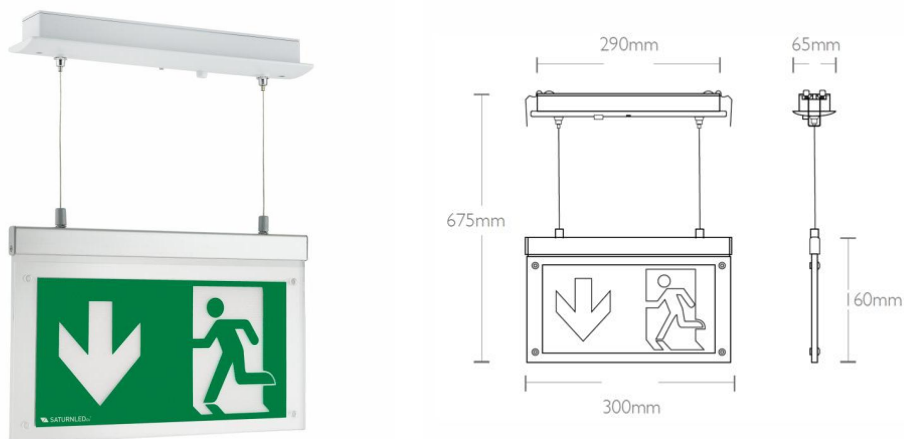

General Details

Finish	Polycarbonate Frame & Acrylate Legend
Product Weight	0.88kg
Overall Dimensions	300mm x 675mm (Suspended)
Carton Weight / Material	1.04 kg / Cardboard
Packaging & Labelling Guidelines	Saturn LED.eu - Generic labelling
Bar Coding	Saturn LED coding in accordance with EAN-12 & ITF-14
IP Rating	IP20
Energy Rating	A* - (Very Low Energy)

Light Source

Rated Wattage	3W
Recommended Product Location	Indoor Emergency Lighting
Light Source Brand	LED
Colour Temperature	6000K
CRI Ra	Ra > 70
Lifespan	30,000 Hours
Lamp Working Temperature	<50°C
Beam Angle	120°
Photometric Data	Visit www.saturnled.eu for full Photometric files
Emergency Duration	3 Hours
Lamp Code	N/A

Electrical

Voltage	220-240V. 50 / 60Hz. AC.
Running Current (I)	0.024A
Total Running Wattage (W)	3W
Electrical Classification	Class II
Power Factor Correction (PFC)	0.38
Cabling Electrical Connections	Screw fix in terminal block
LED Driver	Constant Current AC&DC 90mA +/- 5mA
Battery	
Recharge Period	24 hours

Installation

Distance from Illuminated Object	0.5m
Method of Fix	Ceiling
Recommended Working Temperature	Minimum Temp -10°C to Maximum Temp + 40°C
Instruction Sheet	Supplied with product

Origin & Markets

Country of Manufacture	Designed & tested in Europe - Manufactured in China
Intended Market	Europe, Middle East & Australia 220 - 240Volt

Materials

Main Housing Material	
Fixings Main Housing	Stainless steel screws

Approvals

Warranty	3 Year Warranty - For more information go to www.saturnled.eu/warranty
Marks & Symbols	CE -- SELV -- RoHS -- EMC -- WEEE
Quality Assurance System	SaturnLED quality assurance to ISO9001:2008
Certificate of Conformity	Available on request - technical@saturnled.eu
Manufactured in Accordance to	British Standard - BS EN 60598 - 2 - 22

Datasheet generated from <http://www.electrika.com> last updated Wednesday, February 21, 2018 10:32:15 AM